

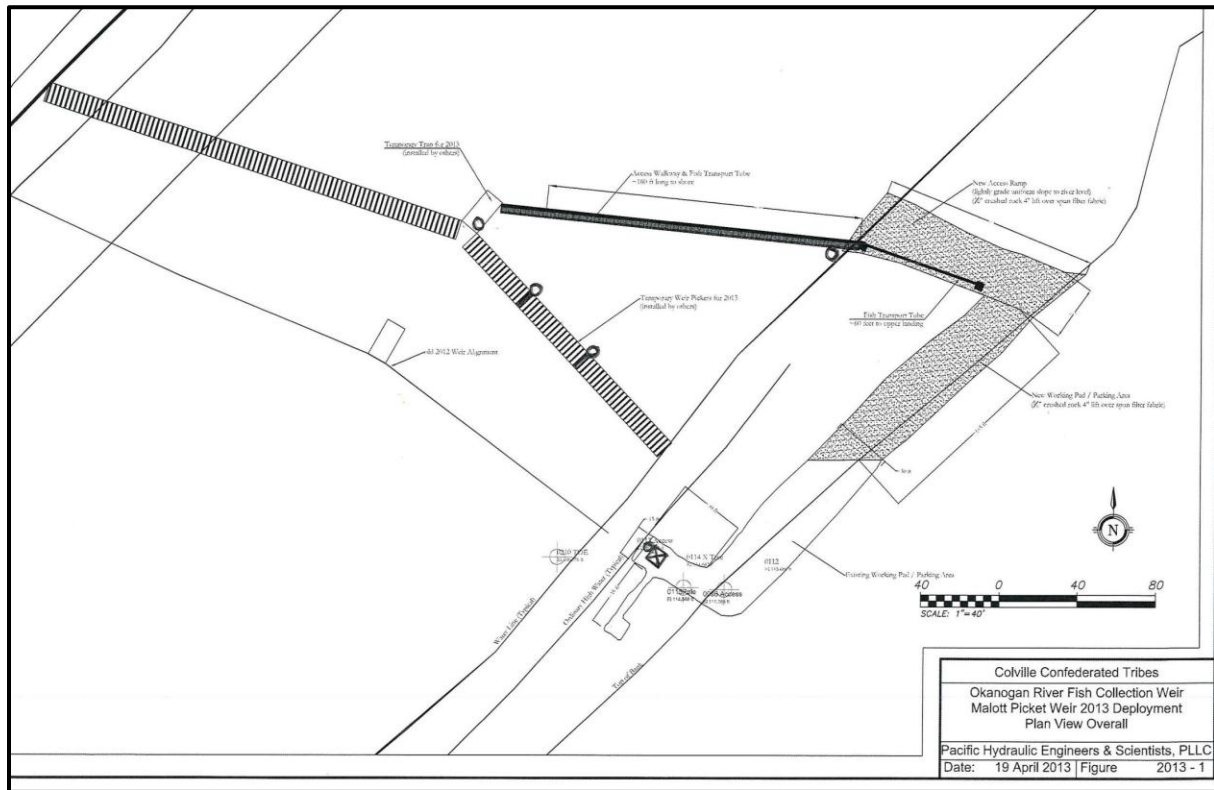

The Chief Joseph Hatchery Program

Okanogan River Adult Fish Pilot Weir *2013 Actions & Operations Plan*



Prepared by:
 Funding Source:
 Agreement No.
 CCT Project No.
 Revised:

Keith Wolf & Andrea Pearl (CCT), Ed Zapel (NHC, Inc.)
 Grant County Public Utility District & Bonneville Power Administration
 430-3128 – Amendment No. 2
 8164-13
 22 May, 2013

Page intentionally blank

ACKNOWLEDGEMENTS

The Confederated Tribes of the Colville Reservation (Colville Tribes, CCT) and leaders from the Chief Joseph Hatchery Program (CJHP) wish to thank the following entities and people for their contributions to this report and their support of the Okanogan Adult Weir pilot project: Bryan Nass, LGL Limited, Ed Zapel, Northwest Hydraulic Consultants, Jeff Grizzel, Tom Dresser and David Duval, Grant County Public Utility District, Linda Hermeston, Peter Lofy and Lori Bodi, BPA, and Jeff Korth, Connie Iten, Carmen Andonaegui and Dennis Beich from the Washington Department of Fish and Wildlife. The program is managed by the Colville Tribes Fish and Wildlife Program and is jointly implemented through a collaborative agreement between the Chief Joseph Hatchery Science Program, Grant County Public Utility District and the Bonneville Power Administration. The Colville Tribes Business Council and the CCT Natural Resources Committee provides policy guidance and oversight. CCT Fish and Wildlife Program participants include: Randy Friedlander, Patrick Phillips, Mike Rayton, Charles Brushwood, Chaitna Sinha, Pete Palmer, John Mayer, Casey Baldwin, Kirk Truscott, Brenda Schmidt, Michelle Campobasso, Cindy McCartney and Billy Gunn. Finally, during 2012, testing of the weir, representatives from state, federal, and the Okanogan Nations Alliance (i.e., Canadian First Nations) visited the project. Their comments and interest contributed significantly to the development of this Plan and will continue to guide activities during 2013 and beyond. Additional individuals and entities are also acknowledged by reference, throughout this document.

Keith Wolf & Andrea Pearl - Spring 2013

UPDATE TO THE 2012 OPERATIONAL PLAN

The Okanogan Adult Fish Weir (i.e., the “pilot weir”) is a key component of the Chief Joseph Hatchery Program. Continued operation and improvements to the weir are a central part of the Colville strategy for the recovery of Chinook salmon and the protection and conserving of sockeye, steelhead and other species, and their habitats, throughout the project area. Further, project test results are essential for updating key assumptions and the guidance derived from the Hatchery Reform Project.

In 2011 and 2012 research, monitoring and evaluation activities led to improvements in design elements and trapping protocols. Additionally, basic equipment procurement, fabrication and site work occurred. Testing of weir components and operations began in 2012 and resulted in approximately seventeen changes and or updates that are being implemented in 2013. This “learned knowledge” approach is inherent in all aspects of the CJHP.

This plan provides action details necessary to test design assumptions and evaluate the need, value and utility of a future permanent structure. As this work progresses, the goal is to have a “working weir” capable of meeting project goals beginning in 2013 through approximately 2017, and or beyond. If a conforming structure, methods and operational plan can be achieved through incremental improvements and optimization, then we expect to designate this as the permanent weir. However, if testing determines that a wholly different design approach is necessary, the working weir must still meet CJHP biological objectives during the subsequent scoping, environmental compliance permitting, and budget and construction phases.

Finally, to ensure regional continuity and consistency with other hatchery and fish management programs, we continue to foster significant involvement of the upper Columbia Public Utility Districts and state, federal and other tribal (i.e., First Nations) fish experts and engineers.

Objectives

The objectives for 2013 are to expand trapping migrating adult summer/fall Chinook to test weir effectiveness, develop adult fish management and brood stock protocols and to continue all research, monitoring and evaluation activities. Further, the project will monitor and manage impacts to non-target species and the immediate environment.

The fate of captured fish consists of the following: 1) Hatchery fish are captured, or released, to meet upstream spawning population and hatchery v. wild composition goals (i.e. recreational harvest, pHOS and PNI targets). Fish from this “adult fish management” activity are destined for upstream fisheries and or used for food distribution and ceremonial purposes by CCT, other regional tribes and the general public; 2) Hatchery and or wild fish are live captured for broodstock (i.e., pNOB, targets). 3) Natural-origin

Okanogan adult summer/fall Chinook are released, unharmed, to spawn upstream in existing and future expanded distribution areas to meet pNOS and PNI biological targets.

A key objective of this project during the 2013-2014 operations, actions and testing is to arrive at a “working” trap configuration, effective protocols and to collect the data necessary to support future environmental assessments, permitting and long term planning. This means that the weir should be operating in a manner capable of helping meet the CJHP’s biological and brood-take goals during the period ~2014-2017 as work continues on design, permitting, funding and construction for a permanent weir. Put simply, it is anticipated that the working weir will operate to adequately support CJHP trapping; adult management and brood take needs and help meet CJHP goals and objectives prior to full working deployment of a permanent weir. To meet these goals, it is likely that the weir will contribute in combination with other capture activities such as seining and from fish ascending the fish ladder, at the CJHP central facility. The CJHP’s tag and mark programs are essential components of these combined efforts.

Finally, in 2013 a set of tests will be conducted to improve protocols for the capture of unmixed “Okanogan” fish (summer run) at the weir site location. A final objective is to access later arriving fish (fall run) to meet genetic integrity and population composition goals. Permitting timelines for this objective may shape the trapping season for 2013 season, but plans and consultations are in progress.

Weir and Trap Changes for 2013

In November of 2012, the CJHP Science Program staff convened a post-season review group to discuss operations and recommendations for improvements/changes. Colville Tribes staff and contract engineers comprised a group of ten experts. The entire season was reviewed and subsequently, data were reviewed with results appearing in the text of this document. The following list of changes have been built into this Plan, the CCT, GPUD, BPA Funding Agreement - Amendment No. 2 and the budget also found in a later section of this document. We envision both pre, and post-season “weir” meetings being called in the same manner as 2012, to occur in 2013. Recommendations from these meetings and the CJHP Annual Program Review’s data analysis will comprise an update and result in the 2014 version of this Actions and Operations Plan.

The following recommendations came from the 2012 post- season meeting and subsequent research, monitoring and evaluation data analysis:

1. Updated and renamed Operations Plan. “2013 Action and Operations Plan” Eliminating the “version” nomenclature. All future plans will be specific to the operational year.
2. Moving trap ~25m upstream
3. Adding ~50 sq. more feet of trap space
4. Adding a half-height crowder
5. Creating a “crowder area” for working up fish.
6. Install three “fate” tubes for moving fish out of the trap.
7. Reconfiguration of trap entrance by adding a second gate.

8. Install two adjustable fykes, one on each trap entrance, to keep fish from existing trap downstream once they enter.
9. Install a temporary fish transport system until a more permanent design is approved by the CJHP. This will serve the objectives for adult fish management of HOR's and for testing broodstock protocols. HOR fish will be released upstream.
10. Trapping hours will be dictated by trap efficiency and numbers of target species. It is anticipated that most trapping and take/release actions will occur during the 1900-0700 time frame.
11. During non-trapping hours, updated video monitoring will enable estimates of trap efficiencies, weir effects, stock-specific behaviors and composition in the trap.
12. Modify weir panel placement. Increased weir panel angle, relative to the stream cross-section, to improve guidance.
13. Addition of cold water for improved entrainment.
14. Dark/camouflage netting cover for trap. Possible improvement of fish entrance into "darker" trap during daytime hours.
15. New access point near approximately ~25 meters upstream into a deeper pool with upstream riffles. This access point will serve as a place for the tower observations the new access, worksite, fish transport and walkway.
16. Observation Tower. CCT staff has a proposed design using a 16ft free standing "tree stand."
17. Walkway to trap that also serves for transport system mounting and additional in-water deflection function for water into the trap. This likely means that the last 20 feet or so of the walkway footing would have some form of semi-permeable grating or other form of design to accomplish objective.

Summary

The Okanogan Adult Fish Weir pilot program is predicated upon the assumption that it will significantly contribute to the CJHP's ability to collect brood and manage adult fish populations, meet biological targets and provide the data necessary to test key planning assumptions. Each year data from the weir, and many other activities, are analyzed, and using run size predictions and updates, staff derives each year's production plan. The central characteristic of the CJHP is that production is not based on the ability to meet the same fixed smolt output or the same escapement goal each year; it is based on our ability to meet the biological goals and validate key assumptions within a program-wide analytical structure. For these reasons, the weir program is operated in a manner where actions are based on testing, and each year's activities are monitored and evaluated in an adaptive management framework.

TABLE OF CONTENTS

Acknowledgements 2

Update to the 2012 Operational Plan..... 3

1.0 Introduction 7

 1.1 Goal of the weir project..... 7

 1.2 Technical Oversight Group 8

2.0 General Specifications 8

 2.1 Species and Timing 8

 2.2 Standard Operating Configurations 9

 2.3 Engineered Weir Panel Failure Mechanism 10

3.0 Daily Activities..... 10

 3.1 Maintenance 10

 3.2 Pollution Control Plan..... 11

 3.3 Debris & Sediment Removal Plan 12

 3.4 Water Temperature Assessment 12

 3.5 Trapping 13

 3.6 Tower Observation..... 14

 3.7 Snorkel Survey 14

 3.8 Video Review 15

 3.9 Weather / Water Assessment..... 15

 3.10 Communications 15

4.0 Evaluations 15

5.0 Adaptive Management 22

 5.1 Standard Protocol..... 22

 5.2 Situations that require initiation of TOG consultation 23

 5.3 Situations that require immediate termination of operations:..... 23

 5.4 Steelhead 23

 5.5 Examples of non-critical situations..... 24

6.0 References..... 24

8.0 Appendix B – Data Sheets 27

9.0 Appendix C – Weir Schematics 40

1.0 INTRODUCTION

This document provides a guide to conducting research, monitoring and evaluation actions and developing long term standard operating criteria for the Okanogan Adult Fish Weir (i.e., “pilot weir”). Daily operations of the weir and other supporting activities are also described.

This program has been developed by the Colville Confederated Tribes’ (CCT) Chief Joseph Hatchery Program. Elements of the program have been refined in collaboration with CJH Science, Production and the CCT Selective Harvest program. Major funding and support for this project comes from the Grant County Public Utility District. The Washington Department of Fish and Wildlife (WDFW) and the National Oceanic and Atmospheric Administration (NOAA Fisheries) are involved in permitting and general aspects of the program developed in coordination with the Northwest Power and Conservation Council, the Bonneville Power Administration and the Hatchery Science Review Group (the “parties”).

The parties agree that it is prudent to proceed with the planning, construction and testing of a weir on the Okanogan River, located between the town of Malott and Chilliwist Creek, approximately 17.5 river miles from the confluence of the Okanogan and Columbia Rivers. The 2013 season’s test will allow the parties to assess the feasibility of constructing and operating a permanent weir in the proposed location and to test potential operation and maintenance procedures and monitoring and evaluation protocols.

1.1 GOAL OF THE WEIR PROJECT

The Okanogan Adult Fish Weir program is predicated upon the CJHP’s ability to collect brood and management of the adult fish populations and meet specified goals for multiple species. For example, the annual CJHP production plan is not based on the ability to meet the same fixed smolt output or the same escapement goal each year; it is based on our ability to meet the biological goals and validate key assumptions within a program-wide analytical structure. For these reasons, the weir program is operated in a manner where actions are based on testing and each year’s activities are monitored and evaluated in an adaptive management framework.

The Chief Joseph Hatchery’s Science Program leads the effort to assess the feasibility of the weir, its biological and physical effects and the management of the weir contracts, engineering, permitting and reporting. Additional activities include research, monitoring and evaluation for safe and effective fish capture, handling, release, and impacts to non-target species. Hatchery and Selective Harvest staff participates in developing significant portions of the project, especially protocols for trapping, capture and transport actions and

the configuration and overall evaluation of the weir to meet the CJHP's biological targets and evaluating the key assumptions used in annual review and decision processes.

The weir is operated as a live capture, live release facility and fish survival is of paramount importance. In addition, the weir will be used to assess installation efficiency, structure stability, operational flexibility, and guidance effectiveness. Supporting activities will be implemented to provide environmental monitoring of the impacts of the structure on migrating fish of the Okanogan.

1.2 TECHNICAL OVERSIGHT GROUP

An informal Technical Oversight Group (TOG), comprised of representatives of the CCT, WDFW (non-listed species), and NOAA Fisheries (listed species), will collaborate to implement the adaptive management aspects of the weir program. More specifically, the TOG will evaluate impacts of the weir program on aquatic resources and may provide timely recommendations to the CCT on project modifications to safeguard aquatic resources and maintain compliance with applicable permits and authorizations. Such recommendations may include, but are not limited to, mitigation measures, termination of weir operations, resumption of weir operations, alternate approaches to accomplishing the goals of the weir project, and modification to numerical adaptive management criteria. A standard protocol for communicating, evaluating, and resolving potentially critical situations through the TOG is presented in Section 5.1. Further, the TOG will be kept abreast of regular activities including notification of weir installation, the beginning and end of trapping periods, and of general observations regarding implementation of the plan. CCT will chair the TOG and manage communications with the group.

2.0 GENERAL SPECIFICATIONS

2.1 SPECIES AND TIMING

Target species for capture: hatchery origin Summer Chinook

Target species for by-pass: natural origin Summer Chinook, Sockeye, Steelhead, resident species

Timing: In-stream structure in place for July, August, and September (Permits currently only cover 1 July through 30 September. October operations are envisioned for accessing later arriving fall Chinook component as proper permits are obtained. The weir will be operational as a fish guidance and or trapping structure 24-hours per day, seven days a week.

Target dates:

- Post-freshet, pre-thermal barrier (approx. 15 Jul)
- Post-thermal barrier (approx. 15 Aug)
- Late run (approx. 7 Sep-Oct in the future as permitting allows)

Actual dates will depend on water discharge, fish migration timing, and water temperature (see JARPA 2011 for details). Our goal is to catch and release HOR Chinook, so the timing of operations need to be based on when they are actively passing the weir location.

- Water discharge: Target installation at approximately 2kcf. Operate to a target maximum of up to 3 kcf. Both targets to be confirmed in the field based on the ability to safely service the weir and process fish.
- Fish migration timing: Target weir operation for trapping when summer Chinook are actively migrating up the Okanogan from the Columbia. To be determined based on catch at the purse seine, and underwater video monitoring at the weir site.
- Water temperature: Migration timing will be influenced by water temperature. Temperatures less than 21 C usually promote active migration, while higher temperatures will slow or stop their migration.

2.2 STANDARD OPERATING CONFIGURATIONS

- A. Weir covers complete wetted width of channel. Three (3) and two (2) inch picket gap panels used in primary migration corridor on east side of trap. One (1) inch picket gap panels used on bank sides of the migration corridor on west side of trap. Two 25' full open gates, each with an adjustable fyke to downstream side of trap. Trap gates closed to capture fish as they enter the trap.
- B. If active trapping spooks fish away from the weir, close the trap gate when a group of fish is in the trap.
- C. If flow refuge or less water is needed through the trap, install a strategically placed solid barrier such as a tarp or wood sheet.
- D. If additional attraction flow is needed through the migration corridor of the weir, install strategically placed solid barrier such as a tarp on the bank side panels of the weir.
- E. If additional attraction flow is needed through the trap, strategically remove pickets and/or open the upstream gate. Gates will be closed simultaneously to trap fish.
- F. If gilled/stuck fish occur in panels, decrease the gap size appropriately as based on observations. Any gilled fish will be released by pulling out adjacent pickets (rather than pushing/pulling fish through the pickets).
- G. If the number of fish approaching or holding at the weir exceeds operational capacity, remove pickets on a panel(s) in the migration corridor.

2.3 ENGINEERED WEIR PANEL FAILURE MECHANISM

Each weir picket panel is designed to support a working load of up to one foot of unbalanced hydraulic head differential, such as might occur if the pickets were clogged with debris. Manual cleaning will be the usual method of removing such debris, by raking up and over the top of the panel or by removing individual pickets as necessary until debris clears the panel. In the event that the panel cannot be accessed manually, a failure mode controlled collapse of the panel has been designed to permit the panel to settle to the stream bed, which will sweep any remaining debris from the picket surfaces without damaging or destroying the panel itself.

The failure mode is designed into the rear leg tripod joint by means of a hitch pin connection. In normal operation, the hitch pin is not overloaded and the panel stands as designed, with the rear leg capable of rotating upstream or downstream as needed to install the panel in a stable configuration. When the hitch pin fails under excessive load, the rear leg connection will be released and the leg will be driven up and out of the connection joint by the weight of the panel and the causative hydraulic load, allowing the two front legs supporting the pickets and picket panel to settle to the stream bed. The rear leg, which is safety-chained to the two front legs, will fall out of the way, but still be attached to the panel so that recovery is straightforward and no damage to the assembly can occur. The panel would be raised back into position and secured by simply replacing the hitch pin once the panel is raised and the rear support leg is repositioned under the connection joint.

3.0 DAILY ACTIVITIES

3.1 MAINTENANCE

Purpose: Provide effective fish guidance and fish-friendly conditions at the weir, including achievement of standard operating criteria. These activities will occur daily while the weir is in the water.

- ✓ Inspect the structural integrity of all in-water weir components.
- ✓ Ensure adjacent panels are abutting and cable connections secure
- ✓ Ensure plastic pickets are driven into substrate and undamaged
- ✓ Ensure anchor system are secure
- ✓ Ensure debris buildup is actively managed to maintain weir alignment and flow
- ✓ Ensure trap connections are secure and overall stability of trap is maintained
- ✓ Ensure access bridge connections are secure
- ✓ Ensure facility warning signs, buoys & lights are in place and functional
- ✓ Provide assistance to recreationalists portaging around the weir
- ✓ Record on-river person traffic.
- ✓ Record any gilled or impinged fish at the weir.
- ✓ Provide project information to recreationalists and visitors

3.2 POLLUTION CONTROL PLAN

Purpose: Protect aquatic and adjacent upland environment at the weir from deleterious substances.

At all times during installation and operation of the proposed weir and trap facility, the CCT will adhere to the water quality standards required under the WAC-173-201A Water Quality Standards for the State of Washington. Specifically, no petroleum-fueled equipment will be refueled within 150 feet of surface water on the site, and an appropriate spill kit will be provided at a prominent and convenient location where it is immediately accessible in the event of a spill. All machinery or equipment to be used near or in the water will be approved for such use, and will be maintained in proper order to prevent spills or leaks of petroleum-based fluids into surface waters. Any heavy equipment operated within the Ordinary High Water Line or within 10 feet of the active stream channel will be provided with biodegradable hydraulic fluids, and kept in clean working order with no leaks. At the end of each workday, all petroleum-fueled equipment (except boats) will be removed from exposure to surface water to a location at least 150 feet away from the active stream channel. We do not anticipate using petroleum-fueled equipment at the site, nor will there be construction or operation liquids at the site to spill. However, training in emergency response to spill events will be provided to work crew prior to commencement of construction or trapping activities. The only waste anticipated at the site is packaging materials which will be recycled or disposed of at the local waste management facility.

The maximum head differential across the pickets will not exceed 0.3 feet over clean pickets. If this differential is exceeded, the pickets shall be cleaned immediately. Average operating river velocity shall not exceed 3.5 ft/s and shall be lower than the velocity at the trap entrance. We will monitor water velocity at the weir site.

The project site has no evidence of progressive erosion. There is no erosion noted in the vicinity of the weir panels, particularly at the upstream toe of the panels and pickets, with its current configuration. The banks are composed entirely of sand, and the channel is predominantly armored cobble. The banks on the upstream and downstream sides of the weir will be stabilized with geo-textile cloth during the period of weir operation, and then removed. Ground screw anchors, with a 500 lb. pullout resistance, will be used to stabilize any portion of the channel affected by the weir or operations. We will install a steel screw anchor on each tripod leg to full depth to ensure maximum holding strength and weir panel stability.

The sediment plume created by deployment shall not exceed 5 NTU's above background at 300 feet downstream of the project location. If the differential exceeds the allowable range, the particular construction activity that is responsible for introducing turbidity will be terminated until mitigative measures can be developed and implemented.

A daily log of turbidity measurements will be updated and maintained on site (Datasheet #9)

3.3 DEBRIS & SEDIMENT REMOVAL PLAN

Purpose: Provide a mechanism to minimize the accumulation or suspension of debris and sediment in proximity to the weir.

No sediment removal is anticipated for this project. Operation of the weir should not cause a need for sediment removal as all sediment passes through the site as fully suspended load. If hydraulic eddies form in proximity to the weir, it may be necessary to redistribute or re-suspend excessive bed sediments after high flow events (which are not anticipated to occur during the period of operation).

Macrophytes and small “beaver” branches are anticipated to be the most substantial form of debris at the weir. Vegetation impinged on the weir will be dislodged and allowed to pass downstream. Any garbage impinged on the weir will be removed and placed in a proper waste bin.

3.4 WATER TEMPERATURE ASSESSMENT

Purpose: To evaluate whether fish trapping and handling can be conducted.

Water temperature at the trap will be measured continuously during operations. The weir and trap will be operated through 22.4°C (72.3°F). When water temperature meets or exceeds 22.5°C (72.5°F), the trap will be closed and sections of the weir opened up for unabated fish passage. We will also use an assessment of fish condition and any evidence of related mortality to decide if the temperature guideline is appropriate.

3.5 TRAPPING

Purpose: Conduct effective and fish-friendly capture, handling, and release of fish to meet adult fish management targets based on HSRG requirements. This includes all fish species (target vs. non-target), regardless of origin (NOR vs. HOR), and for all final dispositions (broodstock, harvested, or released).

1. Operate with upstream gates closed and downstream gates open (until, and unless trap maximum fish holding capacity is exceeded);
2. Handling trough (watered and flowing) and sanctuary dip net in stand-by;
3. Visually monitor for fish approaching the weir and entering the trap through both fykes. Adjust fyke gate opening in accordance with fish species size. Record general observations (e.g. species preference, behavior, etc.);
4. When relatively few fish are actively moving up to the weir, process trapped fish immediately. When relatively numerous fish are actively moving up to the weir, process trapped fish after accumulating no more than 11 Chinook in the trap if water depth is 2 ft and water temperature is less than 20° C (see Figure below). Trap holding capacity is reduced 10% with every degree °F temperature higher, so at 22.4°C, trap capacity must be reduced to no more than 5 Chinook. These capacities are lower if sockeye are also in the trap (5 sockeye = 1 Chinook);
5. A mobile internal crowder with a swinging gate divides the trap into a downstream fish holding section and an upstream work up section. Fish will be crowded down in the holding section.
6. Attendant 1 enters trap at downstream end to net fish into the work up section. Identify Chinook as natural or hatchery origin. Identify Sockeye, Steelhead and other non-targets and enumerate. The first fish to be released will include any Steelhead, bull trout and or NOR Chinook not used for broodstock. They are to be captured by hand or with a net and immediately released upstream;
7. Transfer natural origin Chinook for broodstock to Attendant 2 at sampling trough in upstream working section one at a time for processing). Classify fish condition as 1) vigorous, 2) vigorous and bleeding, 3) lethargic, 4) lethargic and bleeding, or 5) no movement/ventilation;
8. Perform biological sampling of natural origin Chinook including checking marks, tags, fork length and post-orbital hypural (POH) length, age and deformities. Interrogate target fish species with ultrasound to determine sex. If adequate for broodstock, transport fish via fish transport system to broodstock collection truck until biological target is achieved.
9. When transporting broodstock from the weir to the hatchery facility, personnel will employ the Off-Site Brood Collection Protocols, similar those used during Purse Seining brood stock operations, and as defined in the Chief Joseph Hatchery Fish Culture Procedures and Operations Manual.
10. When the daily broodstock quota is achieved, transfer hatchery origin Chinook for adult management to upstream working section. Transport from the trap via fish transport system to selective harvest collection containers until pHOS biological target is achieved. The Harvest Supervisor oversees the allocation of all harvested fish for fresh distribution and delivery to the freezer facility on the same day.

11. Once pHOS biological target is met, release remaining fish safely upstream of trap in low velocity pool.
12. Continually monitor the upstream side of the weir for impinged fish. Capture any live impinged fish in sanctuary net and walk upstream to low velocity pool near trap, and release. Dead salmon washing up on the weir will be inspected thoroughly for spawn condition and cause-of-death assessment. Look for any other potential fish stress indicators such as slamming/jumping at weir panels, descaling, or gilling. Assess whether facilities and equipment provide adequate handling space and post-release conditions. Consider use of a fish tubes or a pen to promote recovery;
13. Reopen downstream gate to continue trapping or continue trapping if the sequester section of the trap is operating correctly;

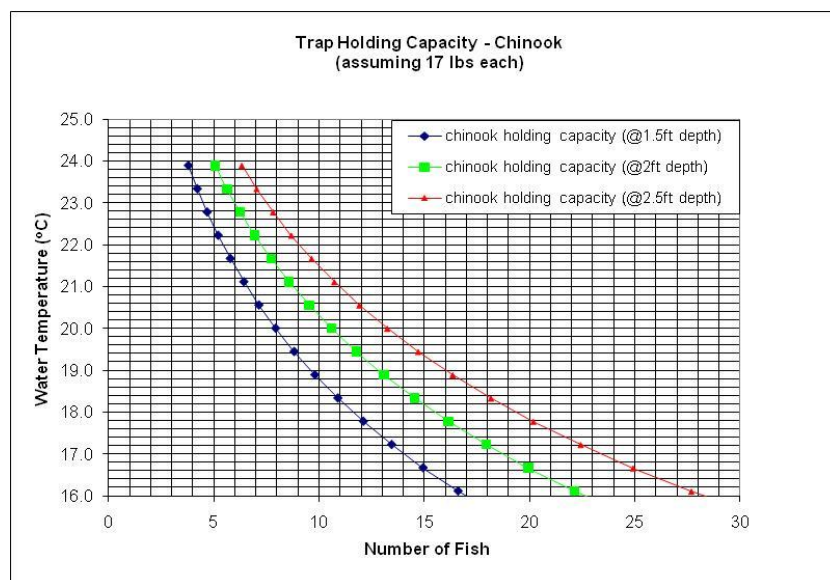

3.6 TOWER OBSERVATION

Purpose: Document events that describe how fish are interacting with the weir.

- One 16 ft. steel tripod tower stationed 20 m. downstream of weir on east bank.
- Conduct visual fish behavior assessment from tripod observation tower using binoculars and high definition video camera.
- 30 minute period, four times per day, during daylight hours.

3.7 SNORKEL SURVEY

Purpose: Look for patterns/trends that indicate fish are actively migrating or holding. This method can be used as an early warning indicator to the weir operators and Project Manager.

- Conduct visual fish behavior assessment and count from weir downstream to Chilliwist Creek (**Datasheet 6**). Count carcasses and cut in half (to eliminate double counting);

- Two times per day (AM/PM), during daylight hours;
- Estimate number of fish by species.

3.8 VIDEO REVIEW

Purpose: Document events that show how fish are interacting with the weir.

- 4-5 underwater cameras with LED lights mounted inside the trap and along weir panels (Appendix C) to identify species, run timing, and behavior. Cameras will be operating 24 hours a day/7 days a week;
- 2 terrestrial security cameras mounted along the walkway and trap (Appendix C) operating 24 hours a day/7 days a week;
- Review underwater imagery of available cameras for previous 24 hours for fish events, and
- Conduct assessment of behavior to infer if the operation is working appropriately.

3.9 WEATHER / WATER ASSESSMENT

Purpose: Anticipate water discharge conditions that could put fish, staff or weir in jeopardy.

- Review weather forecast, looking specifically for potential rain events and high water temperatures.
- Review river discharge and temperature for USGS @ Malott and Nighthawk for pattern/trend. Record water velocities in proximity to weir and the weir staff gauge, and
- Notify senior staff of any concerns.

3.10 COMMUNICATIONS

Purpose: Inform all project staff and the TOG of present operations status.

- Field crew completes the standard information form and distributes it to email list on a daily basis, and
- The Project Manager will be immediately informed of any observations that indicate a potential negative impact to fish health. Critical situations and observations will then be relayed to the TOG the same day.

4.0 EVALUATIONS

The purpose of the weir is to assess the feasibility of safe and effective fish capture, handling, release, and by-pass, and to assess the structural integrity and efficiency of the trap and guidance system. Hence, there are several specific questions that need to be investigated relative to the operation. These questions are partitioned into three topic areas 1) structural design (Table I), 2) operational design (Table II), and 3) fish behavior and passage (Table III). The goal is to collect data that will answer these questions, confirm

adequate performance, or indicate inadequate performance. Specific data sheets will be completed for each type of activity conducted by the weir project (see **Appendix B**).

I. Evaluate Structural Design

Issue Statement	Characterization or Measurement	Method / Approach	Discussion
What are the water velocities in proximity to the weir and trap? (Datasheet #8)	Measure water velocity at various points along the weir on the upstream and downstream side, and in the trap.	Electronic or hand held water velocity meter	<ul style="list-style-type: none"> • NOAA guidelines indicate 1.25 ft/sec maximum • Non-compliance would require adjustment of panel structure, or request for variance
What is the best mechanism and location to provide Free-pass conditions?	Evaluate picket removal, panel removal, gates on trap.	Direct observation	<ul style="list-style-type: none"> • Need to ID the easiest way to provide unabated passage of fish past the weir
What should the gap between pickets measure?	Install test panels of different gap and observe what works best (i.e., pass SO, bar CK, no gilling). 24 hrs of close observation after any major change to confirm no negative impact.	<ol style="list-style-type: none"> 1) Underwater video 2) Tower observation 	<ul style="list-style-type: none"> • NOAA guidelines indicate 1 in. • Nez Perce has used wider gap (2 in.) @ Lostine River facility to pass juveniles • WDFW used wider gaps (1.5 and 3.0 in) on several systems (NOAA approved). 1.5 gilled some fish. (E. Kinne, pers comm.) • Okanogan weir panels need to freely pass Sockeye, but guide Chinook • Have cross-member designs for 1.0, 1.5, 2.0, 2.5, and 3.0 in
Is the size of the trap appropriate for the fish abundance encountered?	Actual trapping experience – too little or too much space?	Direct observation and crew feedback	<ul style="list-style-type: none"> • Max number is 11 Chinook at 20°C, see Capacity table for details • Includes assessment of gate size • It's too small if fish are getting stressed by abundance • It's too big if we are only trapping a couple at a time

<p>Does the picket frame assembly maintain proper tension and picket contact between adjacent frames and with bed substrate?</p>	<p>Observe gap between adjacent picket frame sections. Observe tension on tensioning cable system. Observe picket frame position and inclination. Observe picket base in substrate</p>	<p>Record observations of gap size, misalignment, etc. Record picket frame inclination if it changes over time in response to water/debris load.</p>	<ul style="list-style-type: none"> • Adjust tensioning cable as necessary, if possible • Keep debris off pickets • Replace displaced anchors • Push pickets deeper into substrate
<p>Is trap structure stable and integral? Do panels retain shape? Are structural members adequate?</p>	<p>Observe trap structure stability when loaded with weight of staff/fish being processed.</p>	<p>Note instability and identify cause, if possible</p>	<ul style="list-style-type: none"> • Adjust or reattach structural members as necessary and if possible • Check connections between panels
<p>Is the weir in the best hydraulic position to encourage volitional passage?</p>	<p>Evaluate water velocities and hydraulic transition in proximity to weir, especially downstream.</p>	<p>Direct observation</p>	<ul style="list-style-type: none"> • Will require assessment over a range of flows

II. Evaluate Operational Design

Issue Statement	Characterization or Measurement	Method / Approach	Discussion
Does the weir cause passage problems for human traffic?	Observe whether signage and portage area provide safe passage around weir for recreationalists	1) Direct observation 2) Surveillance video	<ul style="list-style-type: none"> • Document No. of events and outcome • Consider results relative to a permanent weir
Does the weir cause local erosion to the substrate?	Observe for conveyance, compaction. Assess utility of anchor system as mitigation	Direct observation	<ul style="list-style-type: none"> • Document specific locations if persistent or severe • Consider results relative to a permanent weir (partial sill? complete sill?)
Is the size & layout of the trap facilitating efficient processing of catch?	Actual trapping experience	Direct observation and crew feedback	<ul style="list-style-type: none"> • Considers trapping accessories such as dip nets, troughs, gate locations, crowders, access etc.
Can staff readily replace picket frames/pickets with panels of different spacing?	Actual experience with picket frame replacement, individual picket replacement, horizontal support replacement, etc.	Observation and notes on change out procedure and success	<ul style="list-style-type: none"> • Consider observations in future design of improved pickets/frames, etc.
Can staff safely and effectively operate (trap, clean, monitor) the weir over the range conditions encountered?	Actual experience of safe wading and fish processing through complete 24 hr. period	Direct observation and crew feedback	<ul style="list-style-type: none"> • Consider results relative to a permanent weir and what could be done to improve operations

III. Evaluate Fish Behavior, Passage and Condition

Issue Statement	Characterization or Measurement	Method / Approach	Discussion
Are upstream moving fish effectively guided along the weir to the trap?	Observation for patterns of fish moving along the downstream side of the weir.	1) Direct observation 2) Tower observation 3) Underwater video	<ul style="list-style-type: none"> • Aggregation, line ups, drifting? • Differences between species?
Do Chinook or Sockeye enter the trap?	Observation for patterns of fish moving into the trap.	1) Direct observation 2) Tower observation 3) Underwater video	<ul style="list-style-type: none"> • Document behavioral characteristics of entering and non-entering fish. • Numbers by species
Do Chinook or Sockeye use the by-pass section of the weir?	Observation for patterns of fish moving through the by-pass.	1) Direct observation 2) Tower observation 3) Underwater video	<ul style="list-style-type: none"> • Document behavioral characteristics of approaching fish. • Numbers by species. • Close monitoring continues after the weir is opened up for unabated passage to ensure use of by-pass.
What picket gap width allows Sockeye to pass through the weir, but hold up Chinook?	Observation for patterns of fish moving through the by-pass.	1) Direct observation 2) Tower observation 3) Underwater video	<ul style="list-style-type: none"> • Document behavioral characteristics of fish attempting to get through the pickets? (E.g. congregate in specific hydraulic conditions such as high/low velocity, depth, near cover, etc.).
To what extent do Chinook or Sockeye drop back after encountering the weir?	Observation of drop back movements or holding that results in pooling or pre-spawn mortality.	1) Tower observation (near field) 2) Snorkel survey (far field) to Chilliwist Creek, by section	<ul style="list-style-type: none"> • Assume there will be some drop back. • Observation from tower may provide data on No. approaches, No. passes, No. drop backs • Snorkel observation may provide data to assess No. of fish holding and mortalities in downstream pools. • Uncommonly high abundance aggregation or persistent aggregation or mortality of either species may indicate holdup.

Issue Statement	Characterization or Measurement	Method / Approach	Discussion
Do Chinook and Sockeye co-migrate to the weir in time or space?	Counts by species approaching or passing the weir. Observation of approach line.	1) Trap counts, by time 2) Free-pass counts, by time, using underwater video 3) Tower observation to map approach lines	<ul style="list-style-type: none"> • Co-migration will make separation at trap more difficult • Separated migration would make separation at trap easier • Free-pass counts with camera using white board • May vary from year to year
Within a given time frame, does the number of fish (by species) observed below the weir appear to translate into a similar number of fish passing the weir?	Number of salmon below the weir compared to number of salmon passing the weir.	Number of salmon below the weir will be estimated by snorkel survey; number passing the weir according to visual counts of by-pass and trapped	<ul style="list-style-type: none"> • A reasonable time frame for comparative purposes may be 24 hrs. • Relatively similar numbers may indicate suitable passage conditions. • Increasing numbers of fish below the weir may indicate inadequate passage conditions.
Does fish vigor at release decline with increasing water temperature?	Classify level of fish vigor after trapping and handling at trap. Watch for fish impingement on weir after release upstream.	Direction observation	<ul style="list-style-type: none"> • Use same classification scale as seine crew
Is there acute mortality of fish that have been trapped, handled and released at the weir?	Number of dead or moribund fish that impinge on the weir.	Direct observation	<ul style="list-style-type: none"> • Any fish handled at the trap will be marked with a specific hole punch to identify them as such.

5.0 ADAPTIVE MANAGEMENT

5.1 STANDARD PROTOCOL

It is possible that “critical” situations or conditions may develop in which operation of the weir as a functional trapping system needs be terminated or modified to prevent or minimize negative effects on migrating salmon or other aquatic resources. This may include data or observations that indicate the weir or its’ operations may be causing delay in passage, bodily injury or mortality to fish. In these cases, the process of adaptive management for operation of the weir will be conducted through the TOG and guided by five primary steps:

1. Observation – field crew immediately reports a critical situation to the CJHP Project Manager (i.e., Science Program Lead) and provides documentation (who/what/where/when/why/how) of a potential negative impact to fish :
 - a. passage delay (e.g., approach and regress)
 - b. bodily injury (e.g., potentially through jumping, contacting, gilling)
 - c. mortality (e.g., moribund or dead fish impinged or gilled at weir)
2. Project Manager reports the critical situation to TOG and provides a recommendation for mitigative action;
3. TOG Response – Participate in discussion as to what mitigative action best suits the situation. Consensus may be to:
 - a. concur with project managers’ recommended action
 - b. request additional information from the Project Manager
 - c. recommend an alternative action which could include:
 - i. no change to operation and continue monitoring
 - ii. modify operation and continue monitoring
 - iii. temporarily terminate operations, modify operation, and the resume operations with continued monitoring
 - iv. terminate the operation for the season
4. The CJHP’s Science Program’s Project Manager will implement the TOG recommendation(s), and monitor the effect.

All available information will be considered in defining a critical situation and developing a mitigative response. Counts of salmon passing Wells Dam will be considered with respect to the potential relative impact of the weir on the population.

5.2 SITUATIONS THAT REQUIRE INITIATION OF TOG CONSULTATION

1. Observation of any one Steelhead at or below the weir to Chilliwist Creek (see Steelhead below);
2. 50% of fish approach the weir, but return downstream (drop back) in a 30 minute observation period;
3. 50% of fish that approach the weir hold directly below the weir for an extended period of time (e.g., 12 hours);
4. Fish numbers increase progressively in pools downstream of the weir to 3 times the number of fish passing the weir the subsequent day;
5. 5 cumulative fish of any species, alive or dead, are impinged on weir. Cumulative from start – no set timeframe.
6. 5 cumulative fish of any species, live or dead, are gilled/stuck between pickets of the weir. Based on the size class of the fish (Chinook adult, Chinook jack, large Sockeye, small Sockeye) and the specific picket spacing of panel, the TOG may recommend replacement with an alternate picket spacing. Cumulative from start – no set timeframe, and
7. 10 cumulative salmon mortalities in pools downstream of the weir. Note: presently, no information exists on natural mortality in this area for this time of year.

5.3 SITUATIONS THAT REQUIRE IMMEDIATE TERMINATION OF OPERATIONS:

Termination includes closing the trap and opening up weir panels for unabated fish passage. Any incident in this category is reported to the TOG.

1. When water temperature meets or exceeds 22.5°C (72.5°F).
2. Observation of numerous fish holding or pressing on the weir (overwhelming the capacity to normally process fish).

Regular weir operations can be resumed subsequent to termination when recommended by the TOG and approved by the Project Manager.

5.4 STEELHEAD

It is possible that adult Steelhead could be encountered at the weir. Thus, and until the proper permits are secured through NOAA, the weir “season” will be cut short and end on September 30 in 2013. Prior to September 30, the emphasis will be to preempt encounters, minimize contact, and expedite passage in the direction of movement. Preemptive measures will include daily snorkel surveys below the weir during operational periods to look for approaching Steelhead, and staff will also watch the vicinity of the weir for approaching Steelhead. The TOG will be notified immediately of any Steelhead

observed. Steelhead will be provided passage at the weir in the direction of their approach movement by opening gates or removing panels. Steelhead will not be physically handled unless it is necessary for their survival.

It is recognized that information collected on sockeye and Chinook interactions with the weir will inform the operation regarding options for Steelhead, and that the relevant data will be shared with the TOG on a continuous basis. Data will be summarized appropriately to assist in trend analysis. Initial data may support that no change in operations is necessary.

1. 2 Steelhead approach the weir and drop back in a sampling period (i.e., delay of migration by not choosing the trap or bypass route), weir operations are terminated that day. Weir operations resume the next day.
2. 2 Steelhead are impinged on the weir on a day or 3 Steelhead total during a sampling interval of 7 days, weir operations are terminated until directed otherwise by TOG.
3. 2 Steelhead gilled/stuck between pickets on a day, or 3 Steelhead total during a sampling interval of 7 days, weir operations are terminated until directed otherwise by TOG.
4. 1 Steelhead mortality at the weir, weir operations are terminated until directed otherwise by TOG and NOAA Fisheries.
5. 10 Steelhead pass the weir in a day, weir operations are terminated that day. Weir operations resume the next day.
6. 10 Steelhead pass the weir in a day for three days in a row, weir operations are permanently terminated for the year.

5.5 EXAMPLES OF NON-CRITICAL SITUATIONS

1. Fish begin spawning downstream of the weir.
2. Water discharge declines below 1000 cfs and tarps are used to focus flow through the trap or bypass areas of the weir.

6.0 REFERENCES

Nass, B. L., E. Zapel, and E. Rowland 2006. A conceptual proposal for a salmon enumeration facility on the Okanogan River. Report prepared by LGL Limited, Ellensburg, WA for Confederated Tribes of the Colville Reservation, Fish & Wildlife Department, Omak, WA.

JARPA. 2011. Okanogan River adult salmon weir JARPA application. Prepared by LGL Limited, Ellensburg, WA for Confederated Tribes of the Colville Reservation, Fish & Wildlife Department, Omak, WA.

Wolf, K.S. and A. Pearl, 2012. Chief Joseph Hatchery Implementation Plan for 2013. Colville Confederated Tribes, Chief Joseph Hatchery Science Program.

7.0 APPENDIX A - STANDARD OPERATING CRITERIA

NOAA Criteria*	Criteria value	Okanogan River weir value	Meet Criteria Yes or No	Explanation
5.3.2.1 Picket Openings	≤ 1 inch	1 in to 3 in	No	Okanogan weir is designed to evaluate if sockeye can pass through pickets while excluding Chinook. Different gapped panels will be used.
5.3.2.2 Average Design River Velocity	<1 fps, w/ max <1.25 fps through pickets	0.9 to 3.5 fps average; 2.5 to 5.7 fps thru pickets	No	River cross section not large enough to facilitate picket area sufficient to achieve velocity criteria at design flows.
5.3.2.3 Head Differential	<0.3 ft.	≤ 0.5 ft.	Yes	Pickets will be cleaned regularly to maintain head loss within guidelines. Low flow situations may require water barricading adjacent to trap to maintain attraction flows.
5.3.2.4 Debris and Sediment	Plan	Plan	Yes	Debris and sediment will be controlled continuously during trapping periods. The weir will be inspected once per day during non-trapping periods, or more frequently if discharge increases substantially.
5.3.2.5 Picket Barrier Orientation	Lead fish	Angled lead	Yes	Weir designed with 10 to 20 degree lead to trap location. Also takes advantage of shallow right bank vicinity to force fish to deeper water on vicinity of trap.
5.3.2.6 Picket Freeboard	2 feet	≥ 2 feet	Yes	Pickets designed to provide at least 2 ft. of freeboard at high design flow.
5.3.2.7 Submerged Depth	2 ft. for at least 10% of river cross section	0<depth<3ft	Yes	Weir stretches from exposed bar at low flow to deeper thalweg at trap location. Depth depends on flow, but at lowest flow, depth at trap is at least 2 ft.
5.3.2.8 Picket Porosity	40% open area	37% @1" spacing, 64%@ 3" spacing	Yes	Okanogan weir is designed to evaluate if sockeye can pass through pickets while excluding Chinook. Different gapped panels will be used.
5.3.2.9	Flat, round,	ABS 1 ½" in	Yes	Pickets are 1 ½" ABS plastic pipe (black).

Picket material	aluminum, or plastic	pipe		
5.3.2.10 Picket sill	Uniform concrete or other approved	Bed stabilized with anchor system	No	Weir designed as temporary test facility, not permanent. Permanent sill not part of design, nor part of test facility plan. Chain link will be used to stabilize bed if necessary.
6.5.1.2 Trap Capacity	0.25 cu ft. / lb. of fish @ <10°C, minus 5% every °F above	Minus 10% every °F above	Yes	Trap holding capacity dependent on water temperature and water depth in trap. Will require regular monitoring to determine holding capacity during operational periods.
6.9.2.1 Trap Volume	Equation based; or “relatively stable hydraulic conditions”	Volume changes with river stage.	Yes	Trap is porous to the river through pickets and will have similar conditions. Reduced velocity conditions can be achieved by partial blocking at upstream end of trap. Trap is 10ft wide x 15ft long with minimum depth of 18 inches.
6.9.2.1 Trap intake	Fine trash rack <7/8in	Standard 1in picket spacing	No	Trap is porous to the river through pickets and will have similar conditions.
6.9.2.1 Trap freeboard	4 ft. above trap pool water surface at max design	3 ft. above pool water surface at mean flows	No	Mean depth of pool will be 2 ft. Therefore, fish will not be able to jump very high. Further, trap is staffed constantly during operation to remove fish as they enter.
6.6.2.1 & 6.9.2.1 Trap surfaces	smooth	smooth	Yes	All metal edges rounded or ground smooth. Flat surfaces will be fish friendly.

* “Anadromous Salmonid Passage Facility Design”, NOAA Fisheries, 2008.

8.0 APPENDIX B – DATA SHEETS

DATASHEET #1. Daily check list to be completed everyday (including non sampling days). Task can be "ü" if completed with no additional action or "N/A" if the task does not apply for the day (i.e. no panels are in place on non sampling days). Describe the action taken if one is required. One data sheet per day.

DATE: _____ CREW: _____

Task	<input checked="" type="checkbox"/>	Observation and actions taken (if needed)
Ensure plastic pickets are driven into substrate and undamaged		
Ensure access bridge connections are secure		
Ensure minimal shoreline erosion		
Ensure facility warning signs, buoys & lights are in place and functional		
Ensure that lifesaver is accessible and all employees are wearing a PFD		
Ensure adjacent panels are abutting (record gap sizes)		
Ensure panel cable connections are secure		
Ensure no change in panel inclination and shape		
Ensure no debris accumulation on pickets		
Ensure gravel bags are secure		
Ensure trap connections are secure		
Provide assistance to recreationalists portaging around the weir		
Provide project information to recreationalists and visitors		
Ensure impinged fish are removed from the upstream side of the weir		
Ensure a non-detrimental weather forecast for the next day		

Datasheet #4. **Behavior of Chinook (CH), Sockeye (SO), and Steelhead (SH) approaching the weir.** One data sheet per day. Conducted throughout the day and noted in 30 minute intervals. Number of fish Left of thalweg, Center, Right of thalweg. **Searching:** Spend majority of time erratically moving up, down, and/or side-to-side in an apparent attempt to pass the weir (Y/N). **Swam DS:** Immediately or eventually swims back downstream (Y/N). **Stationary:** Spend majority of time relatively stationary (Y/N). **Jump:** Number times jumping or contacting weir. **Guidance:** Guided towards the trap (Y/N). **Panel:** Passed through a weir panel (Y/N) and, if so, which one (P1/P2/P3...). **Trap:** Entered trap box (Y/N).

DATE:		CREW:											
Time	Species	# Fish in Reference to Thalweg			Jump or Contact #	Behavior at Weir			Guidance Y/N	Panel		Trap	
		Left	Center	Right		Searching Y/N	Swam DS Y/N	Stationary Y/N		Y/N	Panel #	Y/N	#
Comments:													
Comments:													
Comments:													
Comments:													
Comments:													

Datasheet #6. **Chinook (CH), Sockeye (SO), and Steelhead (SH) tally between the weir and Chilliwist Creek (~1 km).** One data sheet per day. Survey will be conducted twice a day (10:00, 15:00) in 100 m transects on each by three people swimming downstream. **Live:** Number live salmon observed. **DS:** Number of dead and had been spawning. **DNS:** Number of dead and had not been spawning. **Behavior:** General behavior of live fish.

DATE:			CREW:									
Left Bank			Chinook			Sockeye			Steelhead			Comments (Behavior)
Time	Transect		Live	DS	DNS	Live	DS	DNS	Live	DS	DNS	
AM	A	0-100										
	B	100-200										
	C	200-300										
	D	300-400										
	E	400-500										
	F	500-600										
	G	600-700										
	H	700-800										
	I	800-900										
	J	900-1000										
PM	A	0-100										
	B	100-200										
	C	200-300										
	D	300-400										
	E	400-500										
	F	500-600										
	G	600-700										
	H	700-800										
	I	800-900										
	J	900-1000										
Right Bank			Chinook			Sockeye			Steelhead			Comments (Behavior)
Time	Transect		Live	DS	DNP	Live	DS	DNP	Live	DS	DNP	
AM	A	0-100										
	B	100-200										
	C	200-300										
	D	300-400										
	E	400-500										
	F	500-600										
	G	600-700										
	H	700-800										
	I	800-900										
	J	900-1000										
PM	A	0-100										
	B	100-200										
	C	200-300										
	D	300-400										
	E	400-500										
	F	500-600										
	G	600-700										
	H	700-800										
	I	800-900										
	J	900-1000										

APPENDIX C - WEIR SCHEMATICS

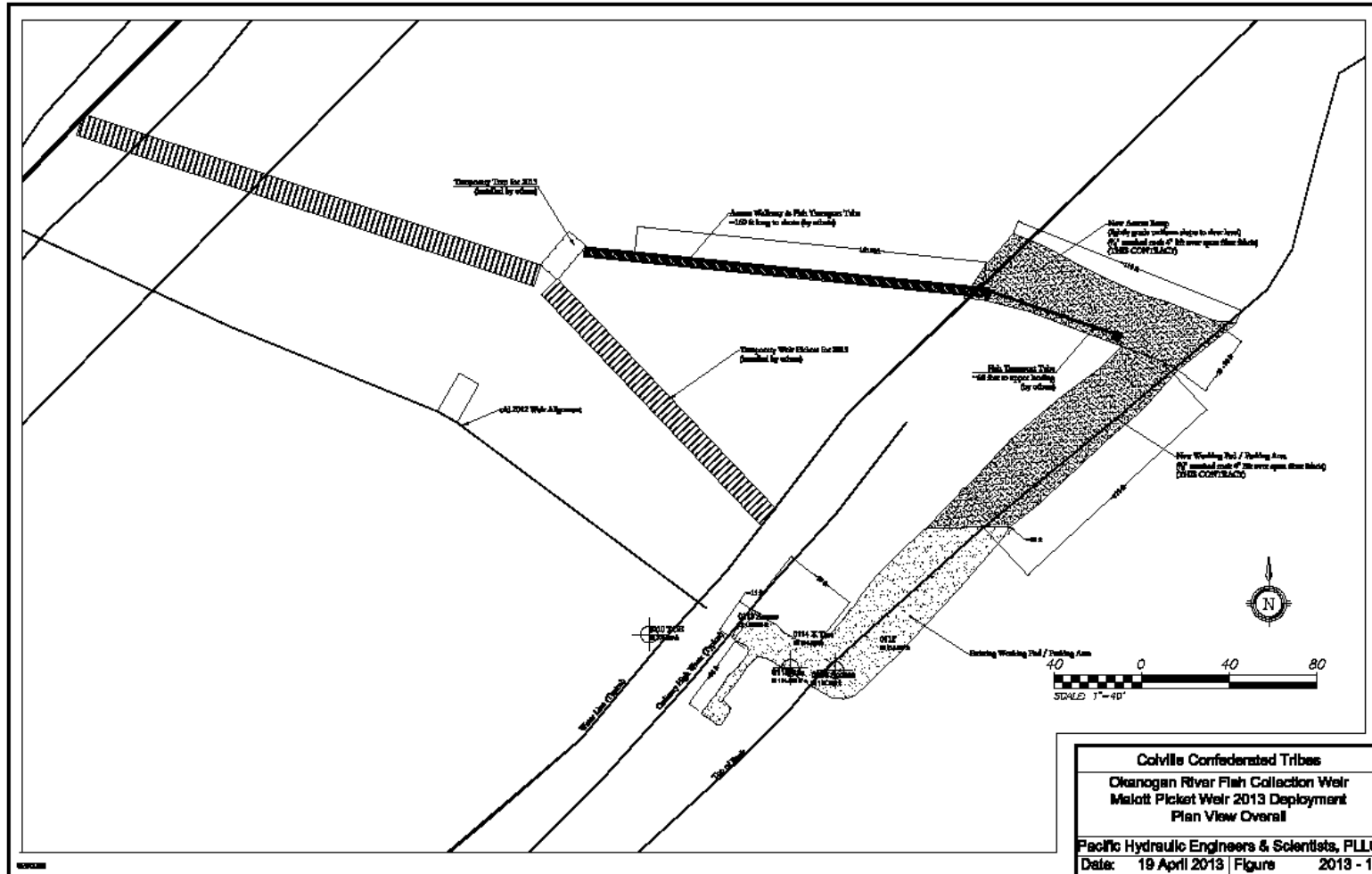

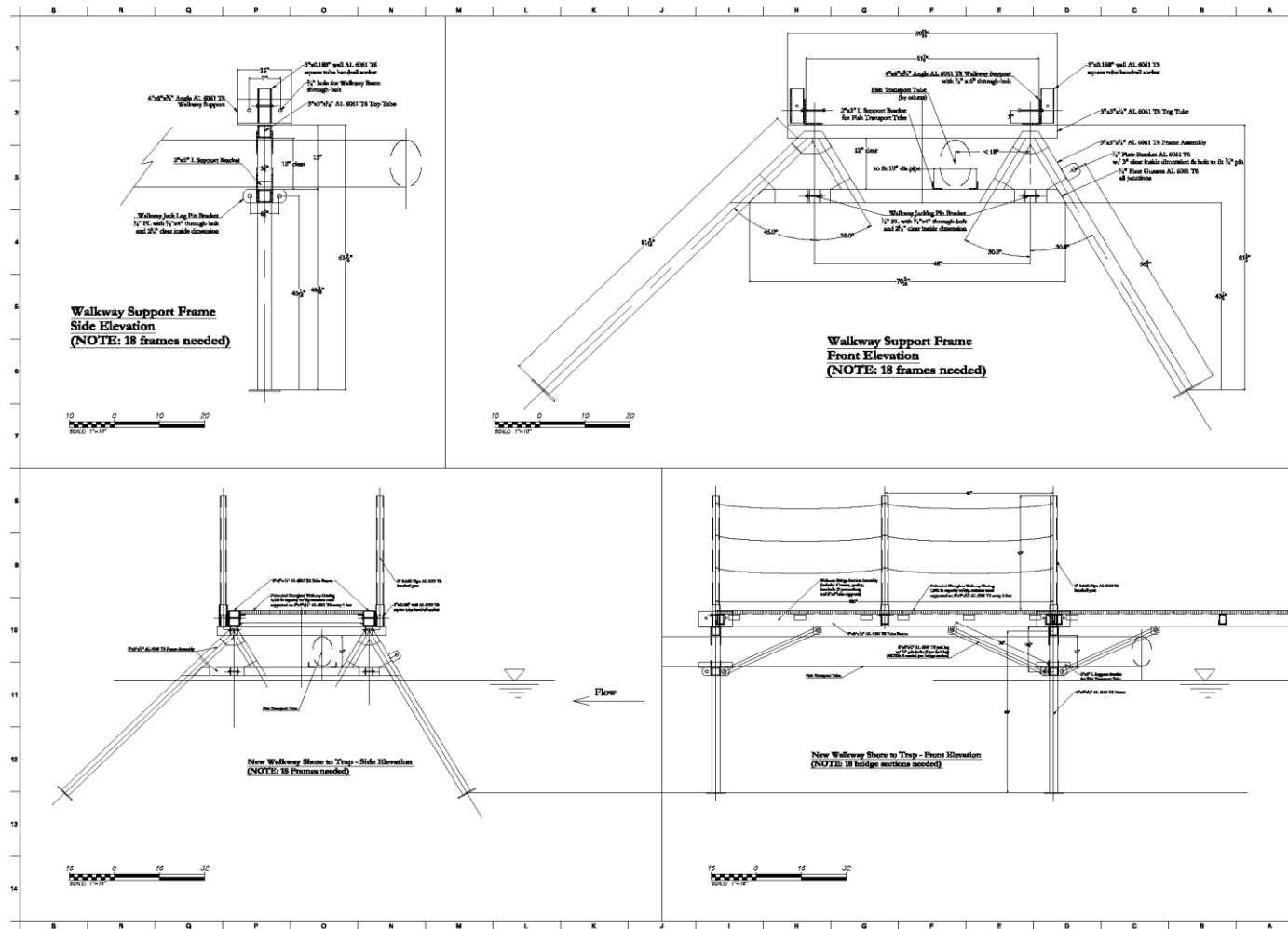

Project
Chinagan River Picket Weir

Client/Agency

Colville Confederated Tribes
Fish & Wildlife Division
22 S. Mission Street
Omak, WA 98841

nhc
northwest hydraulic consultants
15222 Grandview Street
Burien, WA 98148
phone: (206) 291-0200
fax: (206) 298-1423
www.nhcwa.com

NO.	Date	Description
1	3/26/13	DRAFT 3RD Comments

Reviewed/ETC	Design/ETC	Checker/ETC	Checked/ETC

Date: 10 March 2013

Project Name: Access Walkway

Sheet Title: Picket Weir Fabrication Access Walkway to Shore

Reference North	Job Number
	201008
Sheet Scale	Version
	10

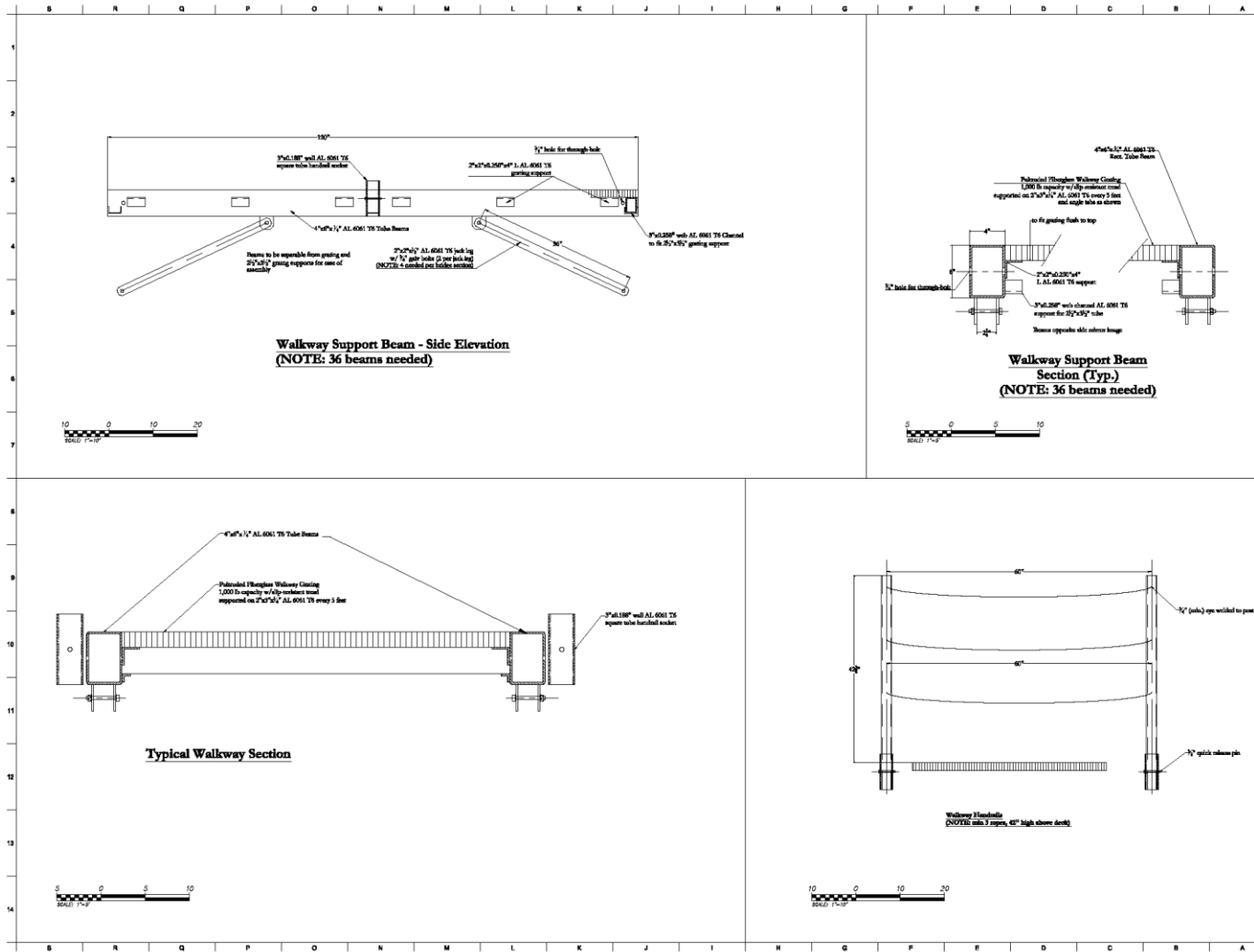

Project
Okanogan River Picket Weir

Client/Agency
Colville Confederated Tribes
Fish & Wildlife Division
25 E. Alexander Street
Omak, WA 98841

nhc
northwest hydraulic consultants
15200 Crestview Road
Burien, WA 98148
phone: (360) 241-8200
fax: (360) 433-3420
www.nhcwa.com

REV	DATE	DESCRIPTION
1	5/20/13	DRAFT 8M Documents

Supervisor/ Designer	Checker	Checked
ETZ	ETZ	ETZ

Date: 02 March 2013
Drawing Name: Access Walkway Details

Sheet Title:
Picket Weir Fabrication
Access Walkway Details

Reference North	Job Number
	200909

Sheet Number
11

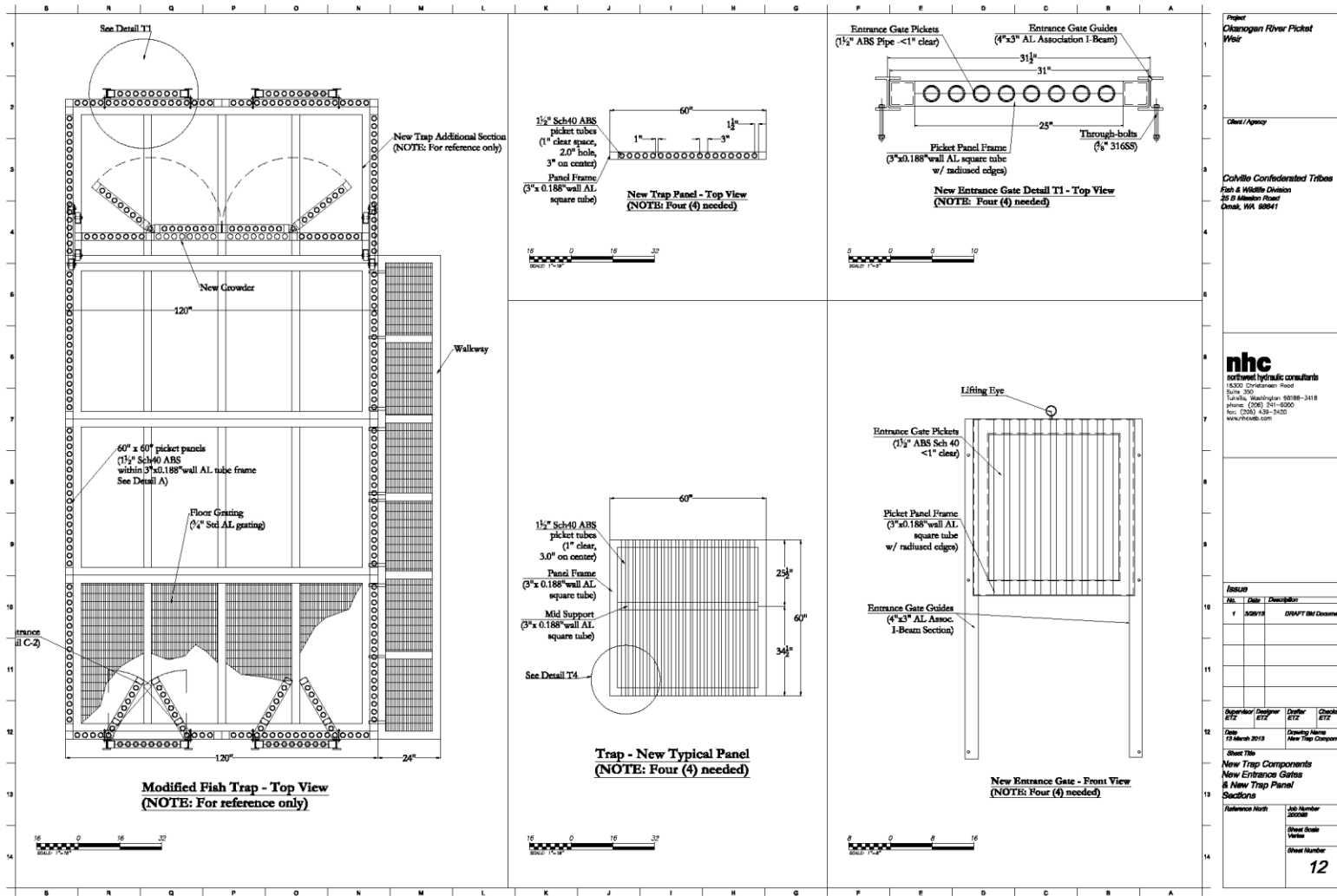

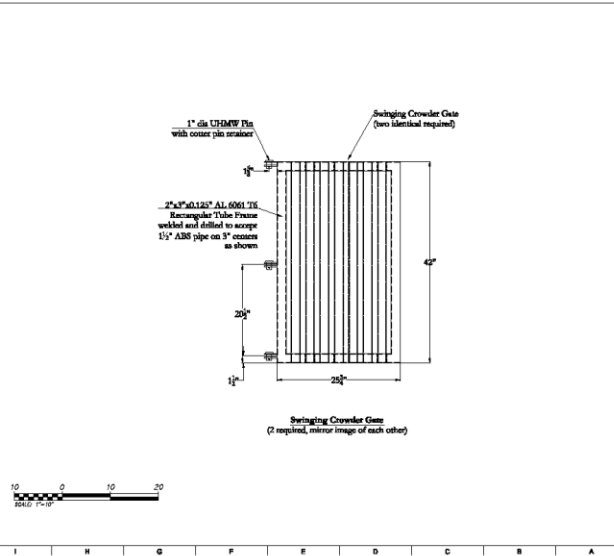
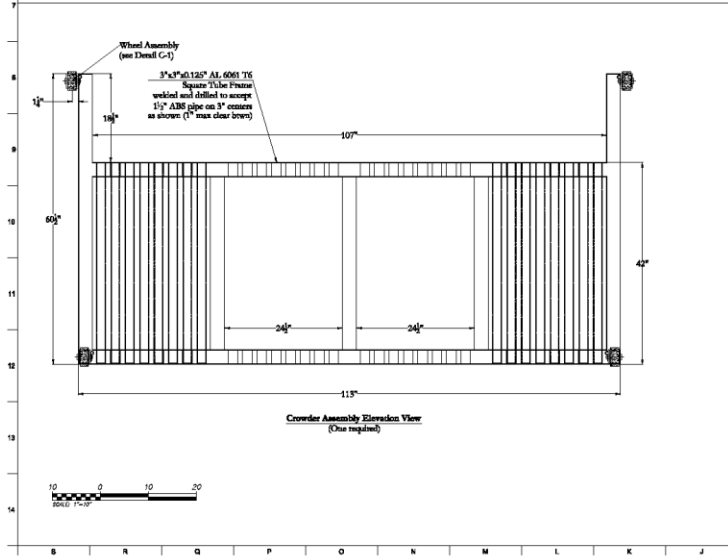
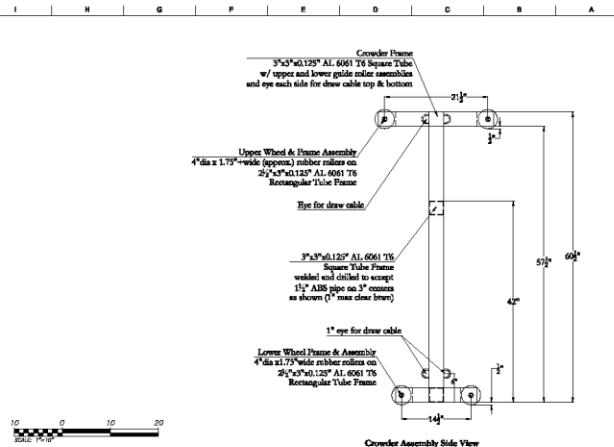
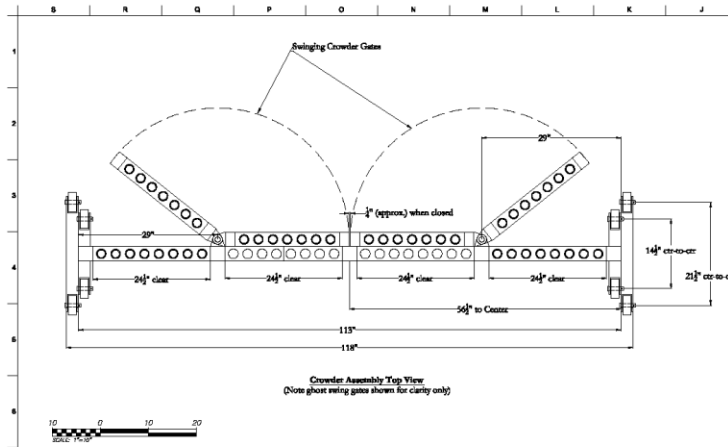

Project Okanogan River Picket Weir										
Client/Agency 										
Colville Confederated Tribes Fish & Wildlife Division 25.2 Member House Omak, WA 98841										
nhc northwest hydraulic consultants 15200 Crestview Road Burien, WA 98148 phone (206) 241-8200 fax (206) 433-3420 www.nhc.com										
<table border="1"> <tr> <th>REV</th> <th>DATE</th> <th>DESCRIPTION</th> </tr> <tr> <td>1</td> <td>02/07/18</td> <td>Bill Documents</td> </tr> <tr> <td>2</td> <td>01/02/20</td> <td>Design Revision</td> </tr> </table>		REV	DATE	DESCRIPTION	1	02/07/18	Bill Documents	2	01/02/20	Design Revision
REV	DATE	DESCRIPTION								
1	02/07/18	Bill Documents								
2	01/02/20	Design Revision								
Supervisor/ ETZ	Designer/ ETZ	Drafter/ ETZ	Checked/ ETZ							
Date 12 March 2018		Drawing Name New Fish Components								
Sheet Title Picket Weir Fabrication Crowder Assembly										
Reference North	Job Number 200689	Drawn Date Not Set	Sheet Number 14							

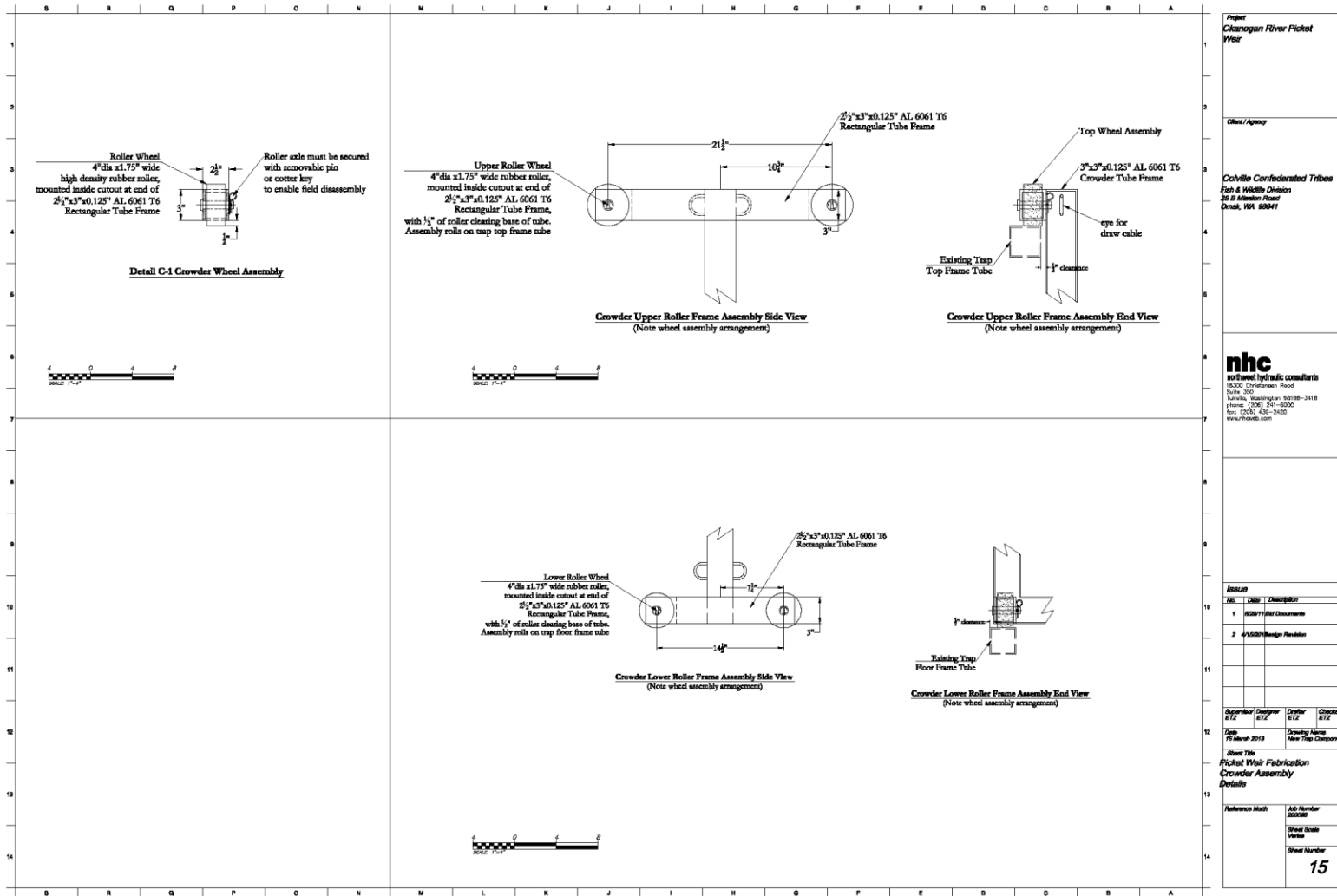

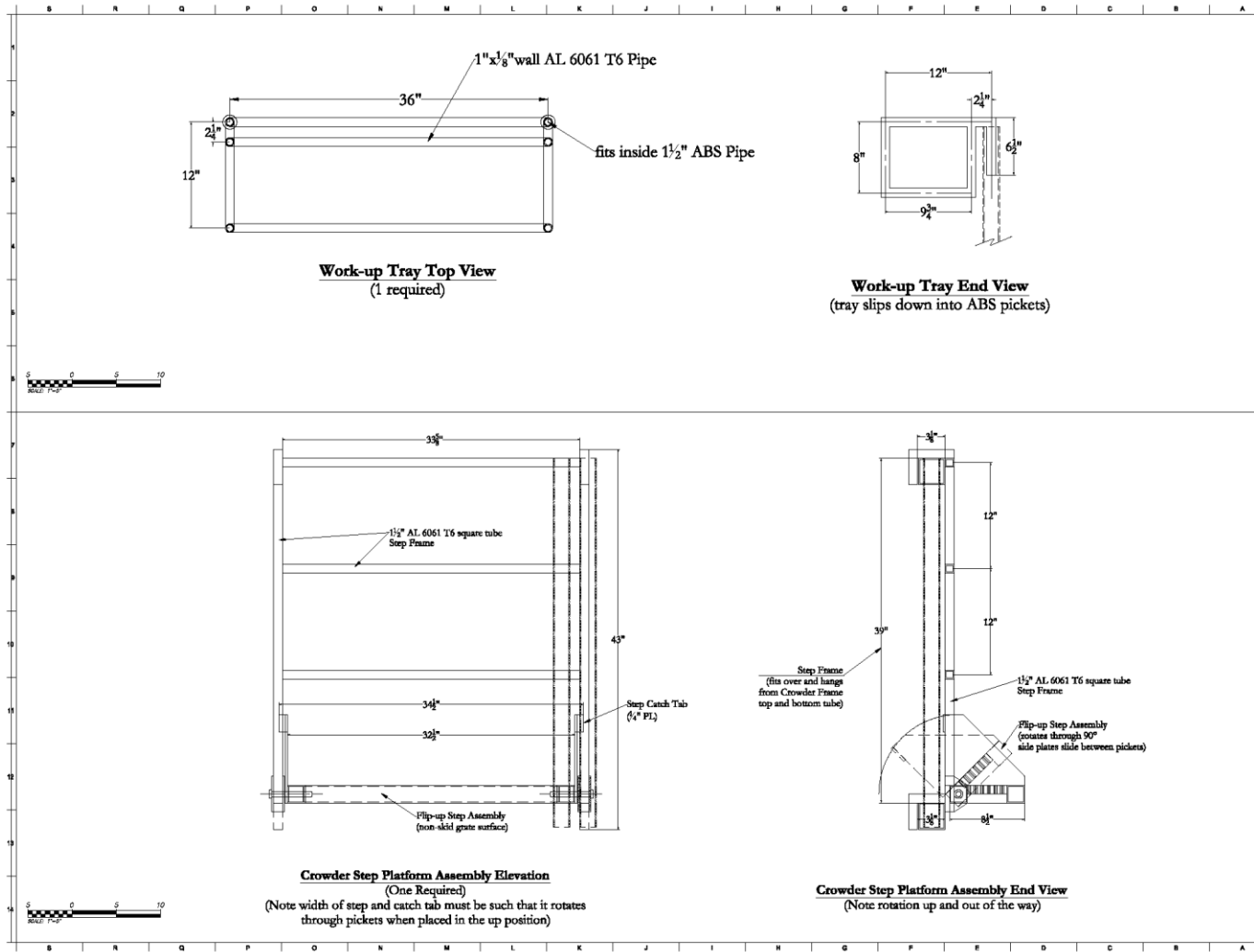

1	Project Okanogan River Picket Weir
2	Client/Agency
3	Colville Confederated Tribes Fish & Wildlife Division 25.2 Alouette Road Omak, WA 98841
4	
5	
6	nhc northwest hydraulic consultants 15200 Covertman Road Burien, WA 98148 Tacoma, Washington 206-888-3418 phone (206) 241-8300 fax (206) 433-3430 www.nhc.com
7	
8	
9	
10	REVISION
11	NO. DATE DESCRIPTION
12	1 02/07/13 Bill Documents
13	2 01/02/13 Design Revision
14	
15	Supervisor/ Designer ETZ ETZ
16	Checker ETZ
17	Date 12 March 2013
18	Drawing Name Picket Weir Fabrication Work Platform Details & Work Up Tray Details
19	Reference North
20	Job Number 200909
21	Drawn Date None
22	Sheet Number 16

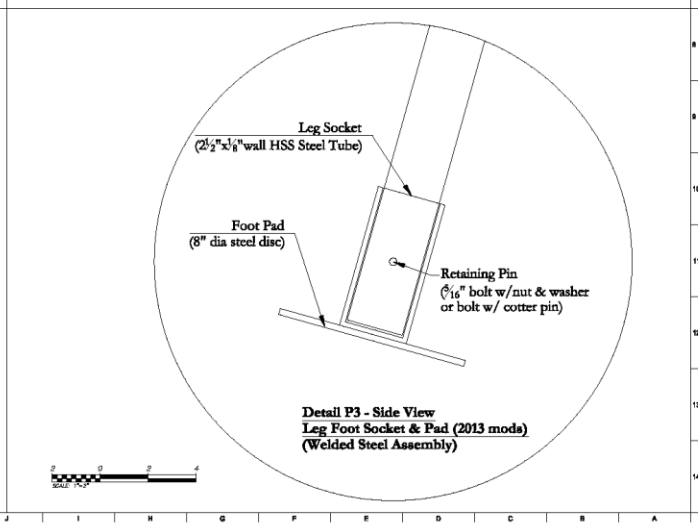
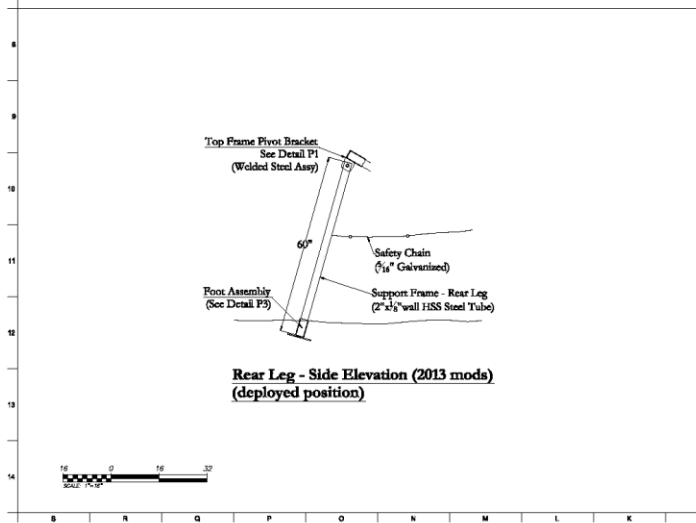
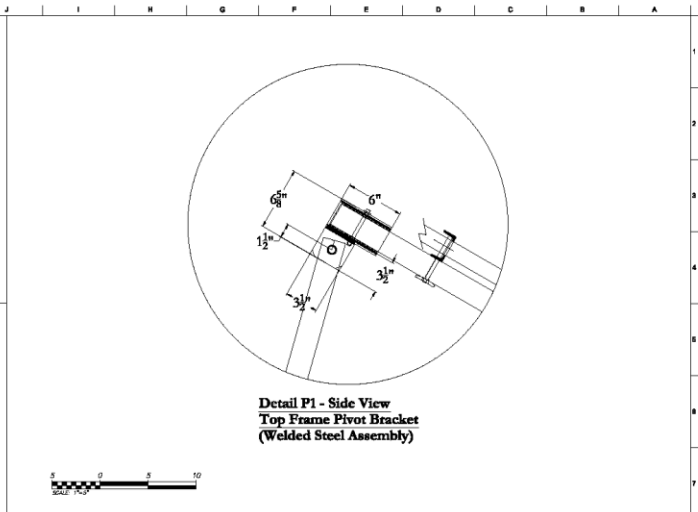
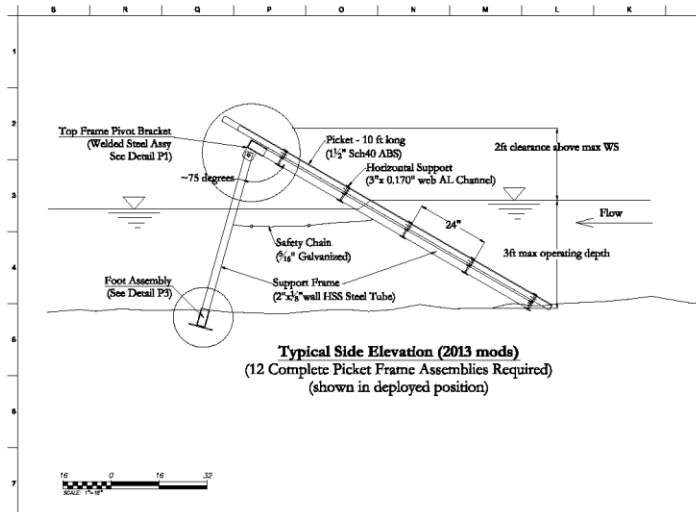

Project Okanogan River Picket Weir			
Client/Agency			
Colville Confederated Tribes Fish & Wildlife Division 25.2 Wheeler Road Omak, WA 98841			
nhc northwest hydraulic consultants 15200 Covertman Road Burien, WA Tulalip, Washington 98148-3418 phone (206) 241-8200 fax (206) 433-3420 www.nhc.com			
DESIGN			
DATE	DATE	DESCRIPTION	
11 Oct 2011		11 Oct 2011 Documents	
		Design Revision	
Supervisor/ Designer ETZ	Designer ETZ	Checked ETZ	
Date 17 April 2013	Drawing Name Picket Weir Fabrication		
Sheet Title Picket Weir Fabrication Picket Frame Component(2013 mods)			
Reference No(s)	Job Number 201206	Drawn/Checked Vetter	
		Sheet Number 17	

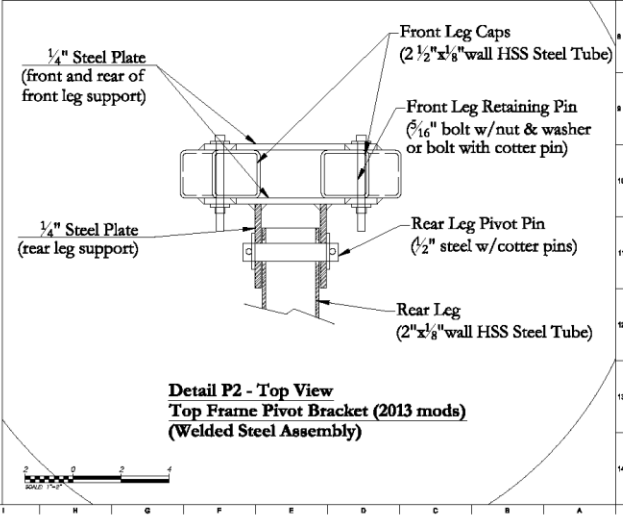
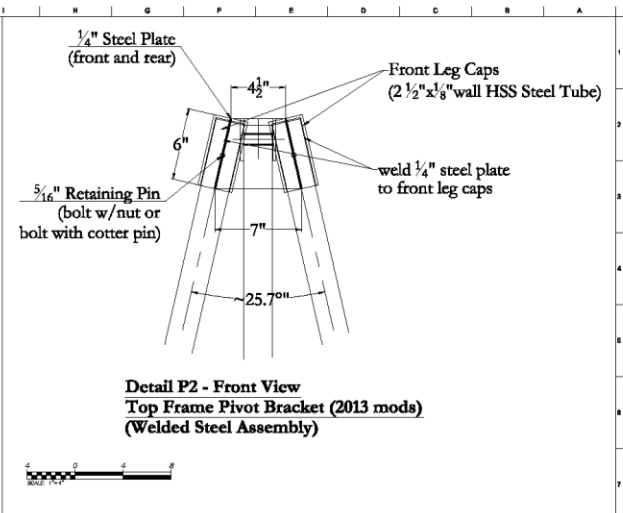
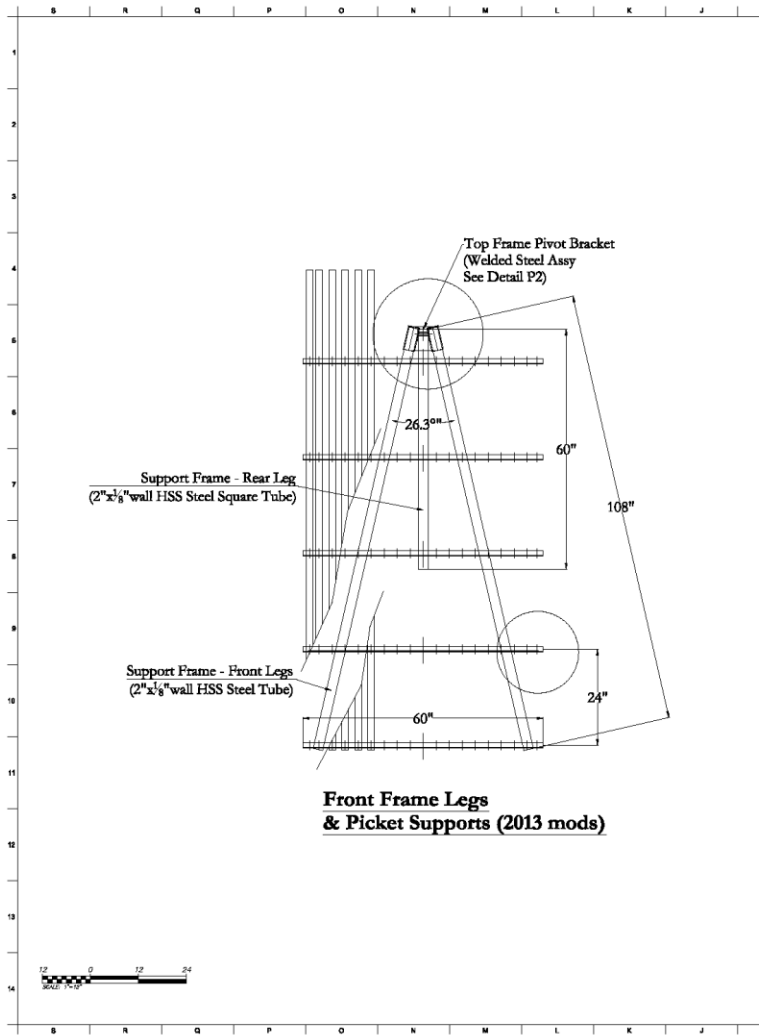

Project Okanogan River Picket Weir			
Client/Agency Colville Confederated Tribes Fish & Wildlife Division 25.2 Wheeler Road Omak, WA 98841			
nhc northwest hydraulic consultants 15200 Coorstenen Road Burien, WA 98148 Tulalip, Washington 800-88-3418 phone (206) 241-8300 fax (206) 433-3430 www.nhc.com			
Revised			
NO.	DATE	DESCRIPTION	
1	15 April 2011	Documents	
Designer: Revision			
Supervisor/	Designer	Drawer	Checked
ETZ	ETZ	ETZ	ETZ
Date	Drawing Name		
17 April 2013	Picket Weir Fabrication		
Sheet Title			
Picket Weir Fabrication			
Picket Frame			
Component (2013 mods)			
Reference No.	Job Number	Sheet Date	
	200909	17 April 2013	
Sheet Number			
18			

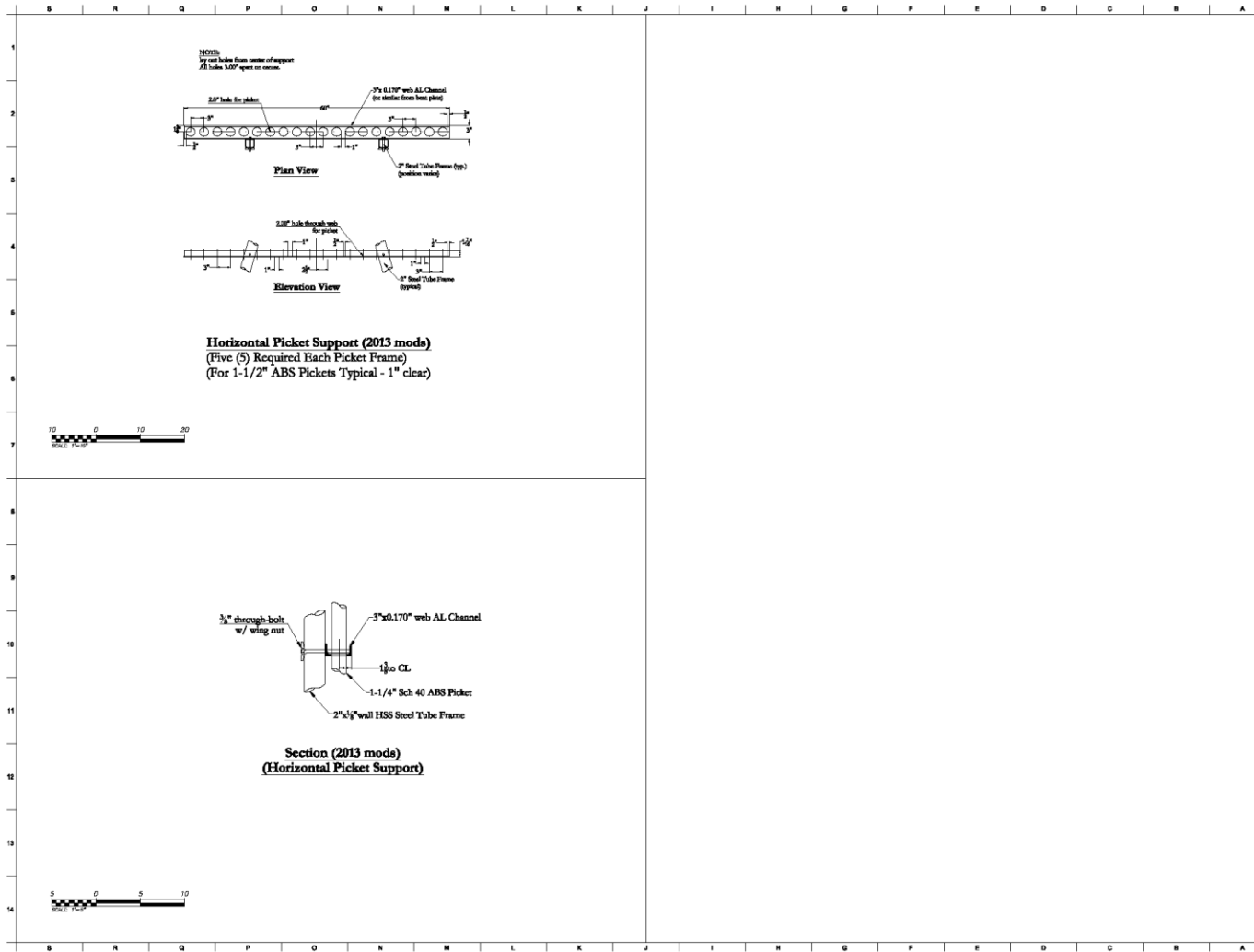

Project
Okanogan River Picket Weir

Client / Agency
Colville Confederated Tribes
 Fish & Wildlife Division
 25.2 Wheeler Road
 Omak, WA 98841

nhc
 northwest hydraulic consultants
 15200 Covertman Road
 Tukwila, WA 98148
 phone (206) 241-8200
 fax (206) 433-3420
 www.nhcweb.com

DESIGN
 1 18 April 2013 BM Documents
 Design Revision

Supervisor/ Designer	Checker	Checked
ETZ	ETZ	ETZ

Date
 17 April 2013

Sheet Title
Picket Weir Fabrication
Picket Frame
Component(2013 mods)

Reference North	Job Number
	2013089

Sheet Number
19